

THE INFORMATION ON THIS DRAWING IS THE PROPERTY OF CELESTRA CORPORATION, IS DISCLOSED IN CONFIDENCE, AND IS NOT TO BE REPRODUCED, USED OR DISCLOSED EXCEPT FOR THE PURPOSE FOR WHICH FURNISHED.

CELESTRA CAT.NO	APP CABLE WIRE RANGE	BOLT SIZE	HEX KEY	A	B	C	D	G	H
AM8135-62	350 kcmil – 800 kcmil	1/2	3/8	±0.03	±0.02	±0.02	±0.015	±0.01	±0.02

NOTES:

- ALL DIMENSIONS ARE IN INCHES UNLESS OTHERWISE SPECIFIED.
- LUG MATERIAL: ALUMINUM ALLOY 6061-T6.
FINISH: ELECTRO-TIN PLATE.
- SCREW MATERIAL: ALUMINUM ALLOY 2024-T4.
FINISH: ELECTRO-TIN PLATED.
- ALL MATERIALS ARE COMPLIED WITH THE RESTRICTION OF HAZARDOUS SUBSTANCES (ROHS) DIRECTIVE (2002/95/EC).
- CONNECTOR IS FOR COPPER AND ALUMINUM CONDUCTORS.

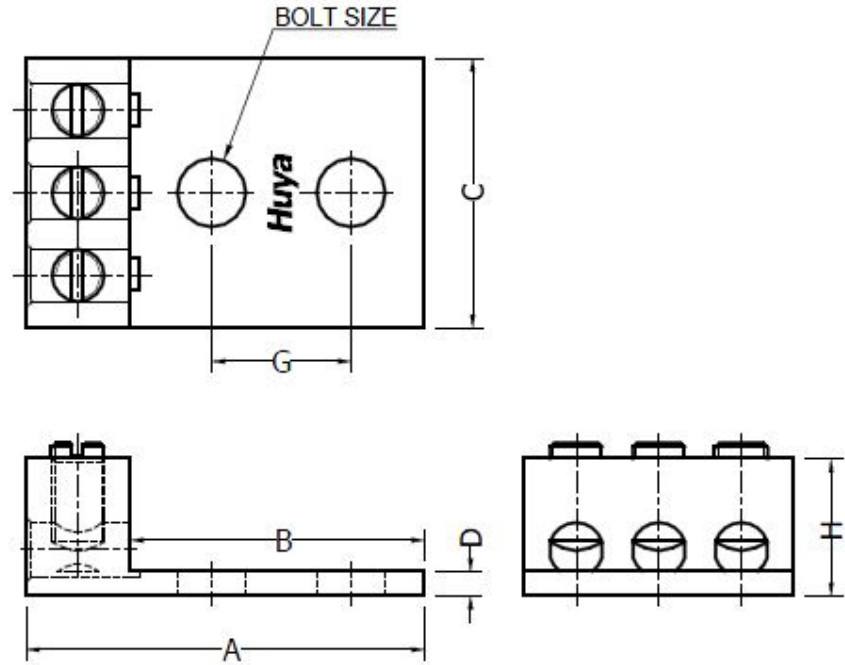

CELESTRA CORPORATION
 76, ZHONGSI HUANCUN ROAD, ZHONGCUN TOWN,
 PANYU DIST, GUANGZHOU, 511495 CHINA
www.celestra.cn

ALUMINUM MECHANICAL LUGS
 350 kcmil – 800 kcmil

REV	DATE	DWN	CHK	DESCRIPTION	ECN
00	25-May-26	Hedy Xiao	Sinia Qiu	Celestra Standards Spec. Initialed.	N/A

MATERIAL	SEE NOTES	PRT. NO.	AM8135-62	SCALE	NTS	THIRD ANGLE PROJECTION
FINISH	SEE NOTES	DWG. NO.	186-0113042478	UNIT	INCH	