

THE INFORMATION ON THIS DRAWING IS THE PROPERTY OF CELESTRA CORPORATION, IS DISCLOSED IN CONFIDENCE AND IS NOT TO BE REPRODUCED, USED OR DISCLOSED EXCEPT FOR THE PURPOSE FOR WHICH FURNISHED.

CELESTRA CAT.NO	APP CABLE WIRE RANGE	BOLT SIZE	HEX KEY	A	B	C	D	G	H
AM3506-34	#6 AWG – 350 kcmil	1/2	5/16	±0.03	±0.02	±0.02	±0.015	±0.01	±0.02

**NOTES:**

- ALL DIMENSIONS ARE IN INCHES UNLESS OTHERWISE SPECIFIED.
- LUG MATERIAL: ALUMINUM ALLOY 6061-T6.  
FINISH: ELECTRO-TIN PLATE.
- SCREW MATERIAL: ALUMINUM ALLOY 2024-T4.  
FINISH: ELECTRO-TIN PLATED.
- ALL MATERIALS ARE COMPLIED WITH THE RESTRICTION OF HAZARDOUS SUBSTANCES (RoHS) DIRECTIVE (2002/95/EC).
- CONNECTOR IS FOR COPPER AND ALUMINUM CONDUCTORS.

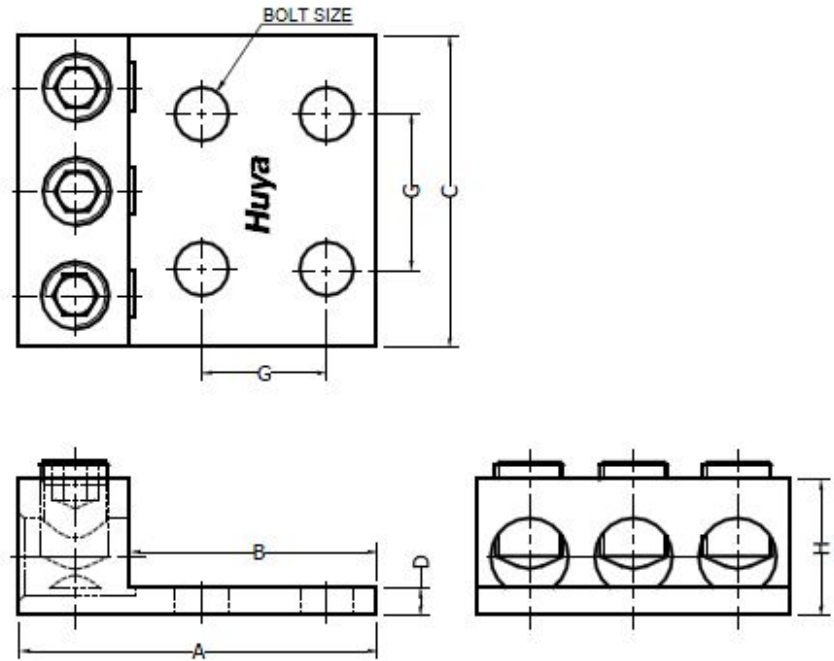

**Huya** | **CELESTRA CORPORATION**  
 76, ZHONGSI HUANCUN ROAD, ZHONGCUN TOWN,  
 PANYU DIST, GUANGZHOU, 511495 CHINA  
[www.celestra.cn](http://www.celestra.cn)

TITLE  
**ALUMINUM MECHANICAL LUGS**  
**#6 AWG – 350 kcmil**

MATERIAL	SEE NOTES	PRT. NO.	AM3506-34	SCALE	NTS	THIRD ANGLE PROJECTION
FINISH	SEE NOTES	DWG. NO.	186-0113042487	UNIT	INCH	

REV	DATE	DWN	CHK	DESCRIPTION	ECN
00	02-Jun-26	Hedy Xiao	Sinia Qiu	Celestra Standards Spec. Initialed.	N/A