

4

3

2

1

THE INFORMATION ON THIS DRAWING IS THE PROPERTY OF CELESTRA, IS DISCLOSED IN CONFIDENCE AND NOT TO BE REPRODUCED, USED OR DISCLOSED EXCEPT FOR WHICH FURNISHED.

CELESTRA CAT.NO	WIRE SIZE		BOLT SIZE	B MIN	C ±0.04	D ±0.015	G ±0.02	H ±0.01
	CODE	FLEX						
DB301434A-250	3/0 AWG	150 Navy 2/0 Weld 325/24 = 131 kcmil 133/.0316 259/.0227 427/.0177	1/4	1.53	0.96	0.13	0.75	0.58

- NOTE:
1. ALL DIMENSIONS ARE IN INCHES UNLESS OTHERWISE SPECIFIED.
 2. ALL DA,DB,LA,LB,WP,AL,AS AND J SERIES OF CAT.NO.S ARE LISTED BY "UNDERWRITERS INC." AND "CSA" FOR USE ON CODE WIRES AND FLEX/24 STRANDED CABLES.

PRE-FIX CAT.NO.WITH "L" HAS NOT PEEP HOLE UNLESS OTHERWISE SPECIFIED IN THE SUFFIX OF THE CAT.NO. WITH "P".

MATERIAL: HIGH CONDUCTIVITY WROUGHT COPPER

FINISH: ELECTOR-TIN PLATE UNLESS OTHERWISE SPECIFIED PER MIL - T - 16366.
SUFFIX CAT.NO.WITH "SP" FOR SILVER.

INSTALLATION GUIDE
DIE CODE = 50
DIE COLOR = Orange

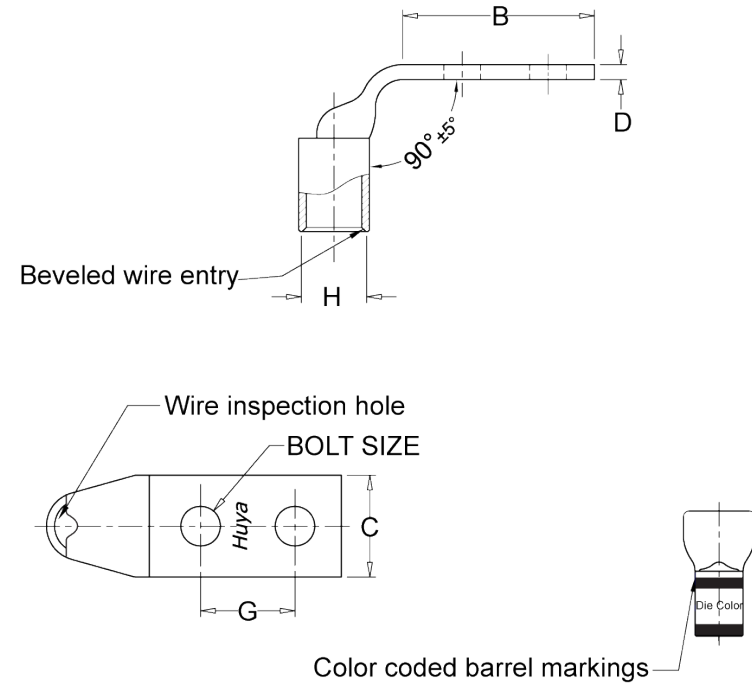

HUYA[®]
www.huyaco.com

CELESTRA CORPORATION

76. Huancun Rd. Zhongcun Town.
Panyu Dist. Guangzhou 511495.

TITLE WIRE CONNECTORS AND SOLDERING
LUGS FOR CODE AND FLEX CABLE

MATERIAL HIGH-CONDUCTIVITY
WROUGHT COPPER

PRT. NO.
DB301434A-250

SCALE
NTS

THIRD ANGLE PROJECTION

FINISH
ELECTRO TIN PLATE

DWG. NO.
186-cp4685

UNIT
INCH



00	05-Apr-26	Ruby Feng	Sinia Qiu	Celestra Standards Spec. Initialed.	
----	-----------	-----------	-----------	-------------------------------------	--

REV	DATE	DWN	CHK	DESCRIPTION	ECN
-----	------	-----	-----	-------------	-----

4

3

2

1