

THE INFORMATION ON THIS DRAWING IS THE PROPERTY OF CELESTRA, IS DISCLOSED IN CONFIDENCE AND NOT TO BE REPRODUCED, USED OR DISCLOSED EXCEPT FOR WHICH FURNISHED.

CELESTRA CAT.NO	WIRE SIZE Code	BOLT SIZE	A ±0.06	B MIN	C ±0.04	D ±0.015	F ±0.02	G ±0.02	ID ±0.01	OD ±0.01	H ±0.02
AL203801-62	2/0 AWG	3/8	3.46	1.89	0.92	0.23	0.44	1.00	0.44	0.67	1.17

- NOTE:
1. ALL DIMENSIONS ARE IN INCHES UNLESS OTHERWISE SPECIFIED.
  2. ALL DA,DB,LA,LB,WP AND J SERIES OF CAT.NO.S ARE LISTED BY "UNDERWRITERS INC." AND "CSA" FOR USE ON CODE WIRES AND FLEX/24 STRANDED CABLES.

PRE-FIX CAT.NO.WITH "L" HAS NOT PEEP HOLE UNLESS OTHERWISE SPECIFIED IN THE SUFFIX OF THE CAT.NO. WITH "P".

MATERIAL: HIGH CONDUCTIVITY WROUGHT COPPER

FINISH: ELECTOR-TIN PLATE UNLESS OTHERWISE SPECIFIED PER MIL - T -16366.  
SUFFIX CAT.NO.WITH "SP" FOR SILVER.

INSTALLATION GUIDE  
DIE CODE = 54  
DIE COLOR = Olive

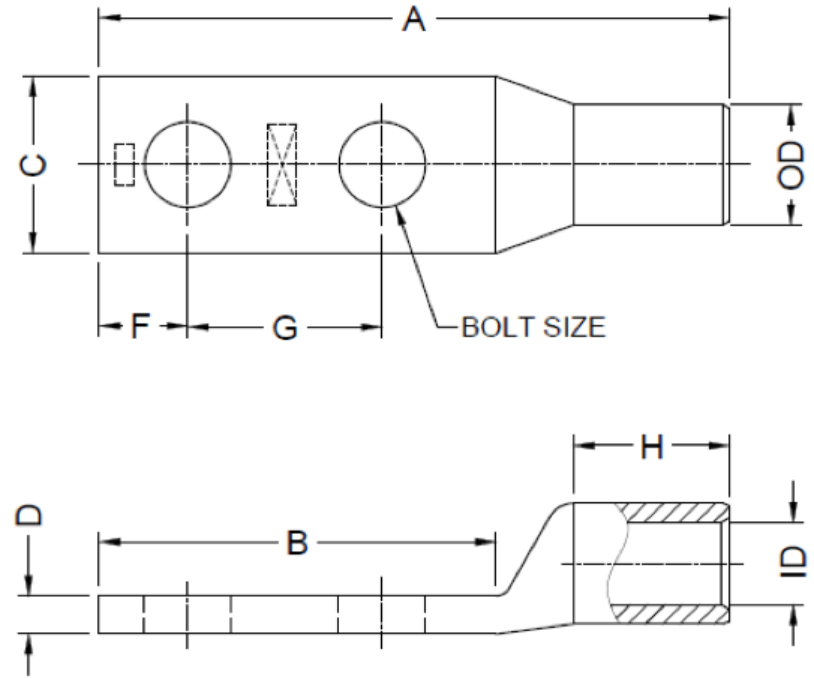

REV	DATE	DWN	CHK	DESCRIPTION	ECN
00	23-Aug-25	Ruby Feng	Sinia Qiu	Celestra Standards Spec. Initialed.	

<b>HUYA®</b> www.huyaco.com		<b>CELESTRA CORPORATION</b> 76. Huancun Rd. Zhongcun Town. Panyu Dist. Guangzhou 511495.	
TITLE WIRE CONNECTORS AND SOLDERING LUGS FOR CODE AND FLEX CABLE			
MATERIAL ALUMINIUM	PRT. NO. AL203801-62	SCALE NTS	THRID ANGLE PROJECTION
FINISH	DWG. NO. 186-cp5197	UNIT INCH	

D  
C  
A

D  
C  
B  
A

4 | 3 | 2 | 1

4 | 3 | 2 | 1